



CE MODEL | SJ 45T



T SERIES Telescopic BOOM LIFTS

Skyjack's world class product designs provide the best possible value and lowest life cycle costs through unsurpassed reliability and ease of service. The SJ 45T boom lift makes no exception to these philosophies, offering proven design features such as Skyjack's standard colour coded and numbered wiring system with analog based controls.

The SJ45T also features Skyjack's exclusive DIRECTIONAL SENSING DRIVE AND STEER CONTROLS, which ensure the boom lift will always drive and steer with respect to the operator rather than the orientation of the chassis.

The axle based 4WD system offers unsurpassed traction and terrainability; using a 'No Spin' differential on the rear axle and limited slip differential on the front oscillating axle.



4X4

T SERIES Telescopic Boom Lifts

Specifications	SJ 45T
Work Height	15,8 m
Platform Height	13,8 m
Horizontal Reach	12,1 m
Platform Size	0,91 x 1,83 m
Stowed Width	2,3 m
Tailswing	0,9 m
Stowed Height	2,4 m
Stowed Length	8,8 m
Wheelbase	2,4 m
Ground Clearance	0,3 m
Platform Rotation	180°
Jib Length	1,5 m
Jib Range +/-	63° / 66°
Weight	7552 kg
Gradeability - 4WD	45%
Turning Radius (Inside) - 4WD	2,1 m
Turning Radius (Outside) - 4WD	5,0 m
Axle Oscillation	0,2 m
Drive Speed (stowed)	7,2 km/h
Drive Speed (raised)	0,8 km/h
Capacity	227 kg
Maximum # of Persons	2

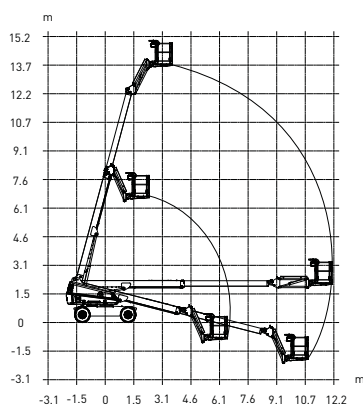

SJ 45T REACH DIAGRAM

STANDARD FEATURES

- Drivable at full height
- Axle based 4WD
- "No Spin" differential and limited slip front differential
- Oscillating axle
- Wet disc SAHR brakes (rear axle)
- 48hp Deutz diesel engine
- Swing out engine tray
- Swing up fiberglass cowlings
- 360° continuous turret rotation
- Direction sensing drive and steer controls
- Proportional controls
- Relay based control system
- Colour coded and numbered wiring system
- 45% gradeability
- 12 x 16,5 grip lug foam-filled tyres
- Wiring for AC outlet on platform
- Tilt alarm with drive cut-out
- Overload sensing system
- Operator horn
- Modular platform railing system
- Spring hinged gate
- Lanyard attachment points
- Tie down/lifting lugs

OPTIONS†

- 3.5kW generator (Includes hydraulic oil cooler)
- Cold weather start kit (Diesel only)
- Diesel scrubber
- Hydraulic oil cooler
- Flashing light
- Platform work heights
- 1/2" airline to platform
- 2WD
- All motion alarm

† Capacities, and machine weights may differ when options are added

Skyjack UK

Unit 1, Maes-y-Clawdd
Maesbury Road Industrial Estate
Oswestry, Shropshire, SY10 8NN
Tel: +44 1691 676235
Fax: +44 1691 676239
Email: info@skyjackeurope.co.uk

www.skyjack.com

Skyjack AB (Sweden)

Marieholmsgatan 2
415 02 Göteborg
Sweden
Tel: +46 31212245
Fax: +46 31212066

Skyjack SAS (France)

Lieudit Les Pretes
22 bis rue de l'avenir
38150 Chanas France
Tel: +33 474 20 30 20
Fax: +33 474 20 58 93

Skyjack Hebebühnen GmbH (Germany)

Wullener Feld 27
D-58454 Witten
Tel: +49 2302 2026909
Fax: +49 2302 2025671

This brochure is for illustrative purpose only and based on the latest information at the time of printing. Skyjack Inc. reserves the right to make changes at any time, without notice, to specifications, standard and optional equipment. Consult the Operating Maintenance and Parts Manuals for proper procedures. CE marked work platforms are in conformance to Machinery Directive 2006/42/EC.

SKYJACK™