

Specifications

MODEL		TZ™-50	
MEASUREMENTS		Metric	US
Working height*		17.09 m	55 ft 6 in
Platform height		15.09 m	49 ft 6 in
Entry height		51 cm	1 ft 8 in
Horizontal reach		8.89 m	29 ft 2 in
Clear outreach		7.04 m	23 ft 1 in
Up-and-over clearance		6.71 m	22 ft
A Platform length		68 cm	2 ft 2.8 in
B Platform width		1.12 m	3 ft 8 in
C Height - stowed		2 m	6 ft 10 in
D Length - stowed		7.16 m	23 ft 6 in
E Width - stowed		1.68 m	5 ft 6 in
F Ground clearance - centre		25 cm	10 in
G Length - outrigger footprint		4.37 m	14 ft 4 in
H Width - outrigger footprint		4.37 m	14 ft 4 in

PRODUCTIVITY		
Lift capacity - standard	200 kg	440 lbs
Lift capacity - rotating platform	200 kg	440 lbs
Jib boom	1.25 m	4 ft 1 in
Jib working range	135°	135°
Self levelling platform	2.5° standard	2.5° standard
Platform rotation option	160° hydraulic	160° hydraulic
AC power to platform	standard	standard
Turntable rotation	359° non-continuous	
Outrigger levelling capability	10°	10°
Drive speed	1.37 km/h	0.85 mph
Gradeability**	20%	20%
Towing speed rate	97 km/h	60 mph
Tongue weight***	100 kg	220 lbs
Surge and parking brakes	standard	standard
Controls	variable speed system	
Tyres	215 R14C	215 R14C
Coupler	50 mm ball coupler standard	

POWER	
Power source - standard	24 V DC (four 6 V 225 Ah batteries)
Power source - drive option	24 V DC (four 6 V 244 Ah batteries)
Power source - option	Hybrid DC/Petrol Honda 5.5 hp (4.1 kW)
Fuel tank capacity	3.6 L 0.95 gal
Hydraulic tank capacity	18 L 4.75 gal
Hydraulic system capacity	30 L 8.0 gal

WEIGHT****	
	2,025 kg 4,464 lbs
Unit weight modifiers for main options	Platform rotation: add 10 kg (23 lbs) Drive option: add 105 kg 231 lbs Bicycle guard: add 15 kg (32 lbs) Full size spare tyre: add 27 kg (60 lbs) Hybrid engine: add 45 kg (100 lbs)

STANDARDS COMPLIANCE CE EN280, PB-10-611-03

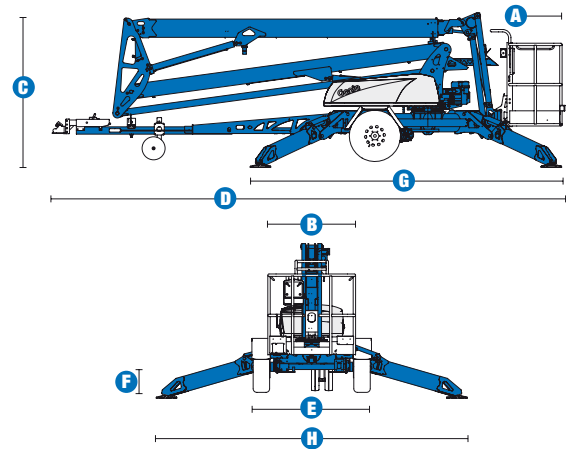

RANGE OF MOTION TZ™-50

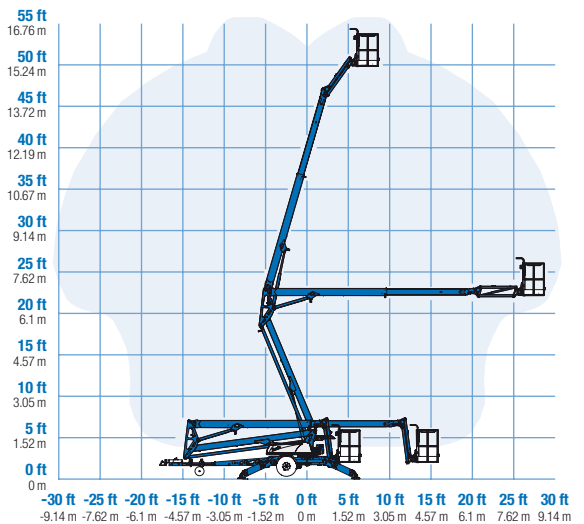

* The metric equivalent of working height adds 2 m to platform height. U.S. adds 6 ft to platform height.

** Gradeability applies to driving on slopes. See Operator's Manual for details regarding slope ratings.

*** Tongue weight will vary depending on options

**** Weight will vary depending on options and/or country standards.

Features

EASILY CONFIGURED TO MEET YOUR NEEDS

PLATFORM OPTIONS

- Aluminium 68 cm x 1.12 m (26.8 x 44 in) platform
- 160° hydraulic platform rotation

POWER OPTIONS

- 24 V DC power source
- Hybrid Honda 5.5 hp (4.1 kW) 45 amp charging system

DRIVE

- Drive option

COUPLER

- 50 mm ball coupler

TYRES

- 215 R14C tyres

STANDARD FEATURES

MEASUREMENTS

- 17.09 m (55 ft 6 in) working height
- 8.89 m (29 ft 2 in) horizontal reach
- Up to 200 kg (440 lb) lift capacity

PRODUCTIVITY

- Industry leading working envelope
- Extension boom
- Self-levelling platform
- 1.25 m (4 ft) jib with 135° working range
- AC wiring to platform
- Hydraulic outriggers
- Automatic 10° levelling system
- Outrigger interlocks
- Mechanical parking brake
- Hydraulic surge brakes
- Auxiliary pump down
- Dual jockey wheels
- 359° non-continuous turntable rotation
- Easy to access batteries
- Hour meter
- Tilt alarm / sensor
- Illuminated outrigger indicators
- Certified load sensor

POWER

- 24 V DC (four 6V 225 Ah batteries) power source



OPTIONS & ACCESSORIES

PRODUCTIVITY

- 160° hydraulic platform rotation
- Drive option with larger 244 Ah batteries pack
- Wheel chocks
- Bicycle guard
- Fluorescent tube caddy
- Full size spare tyre
- Operational warning beacon package
- Non-marking outrigger footpads
- Battery charge indicator (BCI)
- Tool tray
- Bicycle guard*

POWER

- Hybrid Honda 5.5 hp (4.1 kW) 45 amp charging system option

*Standard in The Netherlands

Distributed By:

UK

Millennium House
Brunel Drive
Newark NG24 2DE
UK
Tel: +44 (0)1476 584333
Fax: +44 (0)1476 584334

France

10, ZA de la Croix St. Mathieu
28320 Gallardon
France
Tel: +33 (0)2 37 26 09 99
Fax: +33 (0)2 37 26 09 98

Germany

Finienweg 3
28832 Achim/Bremen
Germany
Tel: +49 (0)4202 8852-0
Fax: +49 (0)4202 8852-25

Spain

Gaià 31, Pol. Ind. Plá d'en Coll
08110 Montcada i Reixac
Barcelona
Spain
Tel: +34 93 572 50 90
Fax: +34 93 572 50 91

Scandinavia

Importgatan 17
422 46 Hisings Backa
Sweden
Tel: +46 31 57 51 00
Fax: +46 31 57 90 20

Middle East

Terex Middle East
PO Box 282325, Dubai
U.A.E.
Tel: +971 4 339 1800
Fax: +971 4 339 1802
Email: InfoME@terex.com

Genie United States

18340 NE 76th Street
P.O. Box 97030
Redmond, WA
USA 98073-9730
Tel: +1 425 881-1800
Fax: +1 425 883-3475

Email: AWP-InfoEurope@terex.com